

Paasche®

TG - TALON Gravity Feed - Internal Mix - Double Action Airbrush

INSTRUCTIONS & PARTS LIST TG-TALON-11/18/2008
Supersedes Instruction & Parts List TG-TALON-8/2008

WARNING: Spray materials may be harmful if inhaled or allowed to come into contact with the skin or eyes. Consult the product label and Material Safety Data Sheet supplied for the spray material. Follow all safety precautions. **CAUTION:** Well Ventilated Area Required to remove fumes, dust or overspray. Secure airhose to Airbrush with V-62 Wrench for safety and to prevent air leaks.
Maximum Air Pressure 75 P.S.I.



INTRODUCTION:

Prime Characteristics of the Paasche® TALON Airbrush include the ability to spray fluids requiring gravity feed doing fine detail and shading work. The Double Action, Internal mix feature permits flexibility in regulation of color and air without work stoppage.

TG Specifications:

- Dual Action
- Head Size .38mm *
- .4 Ounce Gravity Cup
- Hair Line to 1-1/2 Inches
- Crown Cap
- Cutaway Handle with Pre-set Needle Stop
- New Style Trigger and Piston
- * (other Head Sizes .25mm and .66mm)

Working Pressures:

- Operating pressures 20-55 PSI; Maximum pressure 85 PSI
- 20-30 PSI is best for detail spraying w/ properly thinned paint
- Use the higher pressures for thicker material where fine detail is not critical or thin the paint to allow lower pressures.

Equipment Set-up:

The Airbrush is held in the same manner as a pen, with the index finger comfortably over the finger button.

1. Attach air hose to air supply and to airbrush. If using a regulator set pressure between 20 -55 PSI.

Airbrush Operation:

1. Press down on Finger Button to release air and pull back on button to control quantity of color.
2. To spray a fine line without heavy ends, start moving the airbrush without release of color. Then start the color at the beginning of line and stop the color at the end, but continue the motion of the airbrush after the color has stopped.
3. Practice this movement until you can spray a fine line or a broad pattern without heavy build up at the beginning or end of your strokes.
4. Speed of movement controls density of color and fading effects at beginning and end of strokes.
5. For detail, hold the airbrush very close to the surface push down for air and pull back very slowly on the Finger Button to release a small amount of paint.
6. For background work and broad effects, hold the airbrush away from the work surface and pull back on Finger Button to release required amount of color.
7. For Stippling remove the aircap, push down on the trigger and pump the trigger forward and back. Adjust the air pressure between 15 and 50 PSI for desired stipple effect.
8. For more instruction see the "22 Airbrush Lessons for Beginners" booklet enclosed with your airbrush.

Paasche Airbrush Company
4311 North Normandy Avenue
Chicago, IL 60634-1395

Phone: 773-867-9191 • **Fax:** 773-867-9198
Website: paascheairbrush.com
E-Mail: info@paascheairbrush.com

Printed in the U.S.A.

(A)

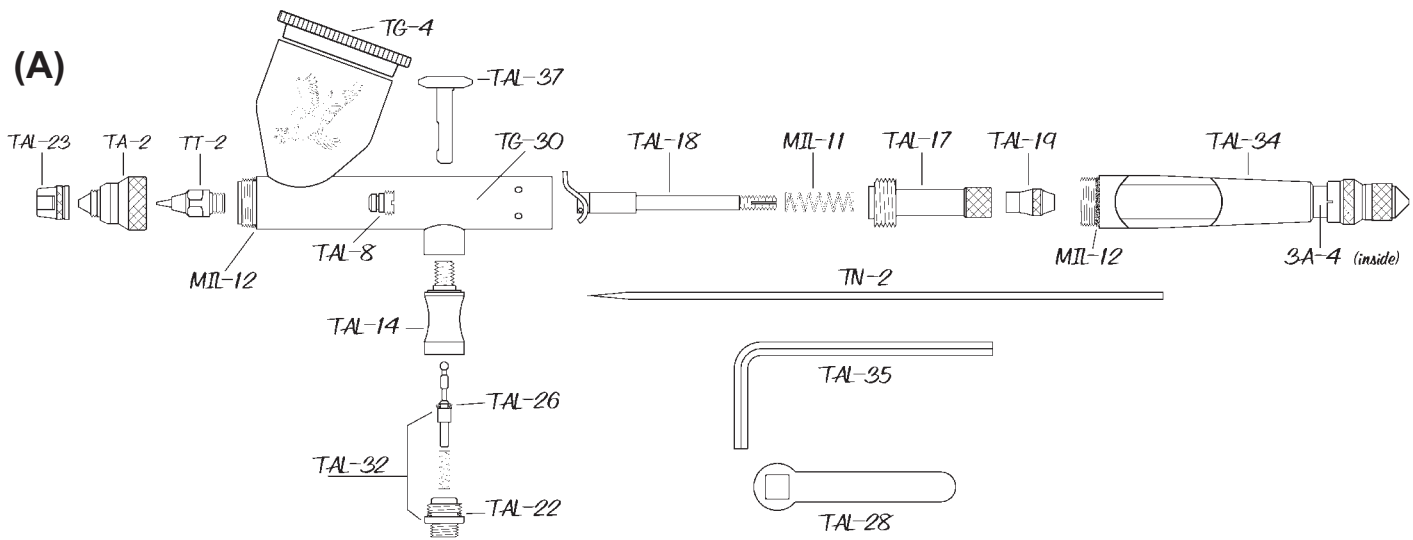

(B)

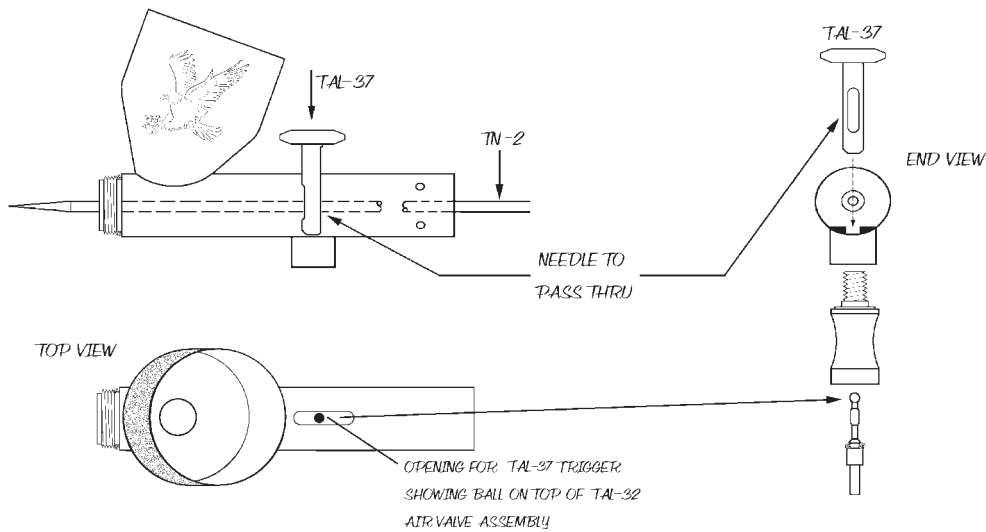

NO.	PART	DESCRIPTION	NO.	PART	DESCRIPTION
1.	TAL-23	Crown Cap	17.	TAL-18	Rocker Assembly
2.	TA-1, TA-2, TA-3	Aircap (.25mm, .38mm, .66mm)	21.	MIL-11	Needle Spring
3.	TT-1, TT-2, TT-3	Tip (.25mm, .38mm, .66mm)	22.	TAL-17	Spring Housing
4.	MIL-12	"O" Ring for TG-30 Shell	23.	TAL-19	Needle Lock Nut
5.	TG-30	Shell Assembly	24.	MIL-12	"O" Ring for TG-34 Handle
6.	TG-4	Cup Cover	25.	TAL-34	Handle & Stop Assembly
7.	TAL-8	Packing Assembly Teflon®	26.	3A-4	"O" Ring
8.	TAL-37	Trigger Assembly	27.	TN-1, TN-2, TN-3	Needle (.25mm, .38mm, .66mm)
9.	TAL-14	Valve Casing	28.	TAL-35	Allen Wrench
10.	TAL-32	Air Valve Assembly	29.	TAL-28	Wrench
12.	TAL-26	"O" Ring			
13.	TAL-22	"O" Ring			

REMOVING / REPLACING THE NEEDLE AND HANDLE (Illustration A):

1. Unscrew the handle and loosen the Locknut-#TAL-19 by turning counterclockwise. Depress the Trigger Assembly-#TAL-37 and hold in Down position while removing or inserting the needle. This assures the needle moves freely through the finger lever. Gently remove the needle, rotating if necessary, Do NOT force out!
2. Inspect the condition of the needle. If it is bent or misshapen in any way, replace it with a new needle. A bent needle can damage or split the Tip-#TT-2 causing bubbles or a rough spray pattern.
3. Hold Trigger Assembly in DOWN position, insert the new needle into the Rocker Assembly-#TAL-18. Gently push needle through, rotating if necessary, push gently forward until the needle stops in the front of the tip.
4. Release Trigger Assembly and tighten Locknut by turning clockwise.

REPLACING THE FINGER LEVER ASSEMBLY (Illustration B):

If the Trigger Assembly -#TAL-37 is removed, it is easiest to replace before the Rocker Assembly-#TAL-18 is inserted. The needle must be removed.

1. Hold Trigger Assembly so the round side of the stem is to the front and flat side to the back of the airbrush (see B - END VIEW).
2. Insert Trigger Assembly straight DOWN through the opening in the top of the airbrush shell (see B - TOP VIEW).
4. You want the bottom of the trigger to cover the round ball on top of the exposed plunger. Once the connection is made you should have spring action when pushing down on the trigger. Proceed to replace Rocker Assembly and balance of parts as above. When the needle is inserted it will prevent the removal of the finger lever.

REPLACING THE TIP:

1. Remove handle, loosen Locknut-#TAL-19 and withdraw needle about one inch (1").
2. Un-screw the Aircap-#TA-2 and remove. The Tip-#TT-2 can now be Unscrewed with wrench #TAL-28.
3. Place a new Tip into position and tighten with wrench. The tip must be very wrench tight. Finally push the needle forward until it is seated fully forward into tip.

ADJUSTING WORN PACKING WASHER:

1. If Packing Washer-#TAL-8 becomes worn or loose it must be tightened or replaced.
2. Tighten Packing Nut with small screwdriver. To reach packing all internal parts must be removed.
3. Replace needle and make sure Packing Nut is not too tight. A slight resistance to movement is needed when needle is passed through.
4. Completely re-assemble guts of airbrush.

CLEANING THE AIRBRUSH:

1. Spray airbrush cleaner through airbrush until it has no more color spraying out of airbrush.
2. Remove needle and wipe clean then replace.
3. If paint has dried for a time you can remove the front tip, and aircap for soaking or soak just the front of the airbrush in cleaner.
4. Any paint cleaner is fine. Keep trigger area dry if soaking.

PERSONAL SETTINGS:

Spring Housing #TAL-17 Used to increase or decrease spring tension for the trigger pull back. Thread into the shell until the trigger stroke feels comfortable. Threading in until it stops can cause the trigger to jam.

TROUBLESHOOTING:**Bubbling in cup:**

1. Aircap #TA-2 needs to be tightened
2. Tip #TT-2 needs to be tightened further

Skipping or Spitting:

1. Paint too thick -Reduce with thinner
2. Tip not seated -Tighten Tip#TT-2 with wrench
3. Tip split or damaged Needle -Replace tip or needle
4. Needle or tip dirty -Clean and replace
5. Air pressure too low -Increase pressure or thin paint further (need 20 or more PSI to spray most paints)

Airbrush Not Spraying:

1. Clogged Tip -Remove tip and clean
2. Needle not moving -Tighten needle locknut
3. Low air pressure -Increase pressure (need 20 or more PSI to spray most paint)

Sprays double line or heavy to one side:

1. Split tip or bent needle - Replace
2. Dirty tip or needle - Remove and clean

Jammed trigger or poor trigger motion:

1. Adjust Spring Housing - Screw or unscrew the housing to lessen or increase tension on trigger motion
2. Paint leaking to trigger area - Remove guts of airbrush and slightly tighten packing or replace if needed

ACCESSORIES

- 36. **A-34** Hanger
- 37. **V-62** Wrench

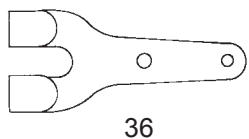

36

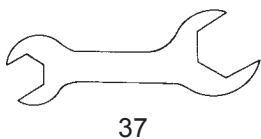

37

AIRHOSES W/FACTORY INSTALLED COUPLINGS

- 34. **A-1/8** Braided Airhose W/Couplings
- 35. **HP-1/8** Red-Plastic Airhose W/Couplings

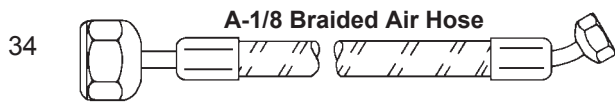

34

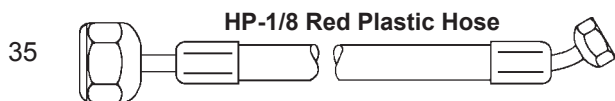

35

**AL-2, 2.4 fl.oz., (85ml)
PAASCHE AIRBRUSH LUBE**



MT MOISTURE TRAP INSTALLATION

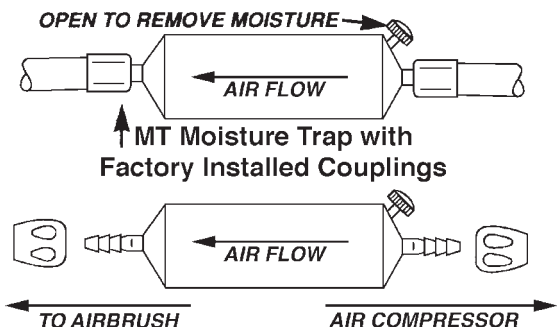

Do-it-Yourself Installation: The Moisture Trap is designed for use with all Airbrushes to remove water from the airline. To install-cut the airhose about 18" from the Airbrush coupling and insert as illustrated.

Recommended Compressors and Accessories



D200R AIR COMPRESSOR (1/6 H.P.)
with Switch UL Listed & R-75 Regulator
Perfect for hobbies requiring increased pressure for atomizing heavier materials. Delivers up to 35 psi operating pressure. It operates on 115 Volts, 60Hz, 1.5AMPS and delivers .7 CFM @ 20 psi.
Shipping Weight: 13 lbs. (5.9 kg)



D500 AIR COMPRESSOR (1/8 H.P.)
(ETL Listed)
Economical and suitable for all airbrushes spraying properly thinned fluids. It is capable of delivering up to 35 P.S.I. operating pressure depending on airbrush being used. The Paasche D500 is an oilless piston compressor. It operates on 110-120 Volt, 1 phase, 60Hz, and delivers .4 C.F.M. @ 20 P.S.I.
Shipping Weight: 8 lbs. (3.6kg)



DA300R AIR COMPRESSOR (1/6 H.P.)
with Switch CSA approved & R-75 Regulator
1/8 H.P. Piston Compressor with Auto shutoff. Compressor shuts off when airbrush is not in use. Operating pressure is 20 - 30 P.S.I. depending on airbrush being used, delivers up to 35 psi. 120 VAC, 1 Ph, 60 Hz, 1.4 A, 20L/Min. (0.7CFM), Noise 53dB, 1720 rpm.
Shipping Weight: 9.14 lbs. (4.6 kgs)



D3000R AIR COMPRESSOR (1/8 H.P.)
(ETL Listed)
This piston compressor is a tank mounted unit, designed for compactness and portability. The sturdy air tank stores reserve air volume and reduces pulsation. Air pressure in the tank is regulated with an automatic on/off limit switch to a maximum of 40 P.S.I. Unit maintains 30 P.S.I. for extended periods. The unit has a five foot grounded 3 wire cord.

The compressor features a 1/8 HP motor which operates on 115 Volts, 1 Phase, 60Hz and draws .9 AMPS.

Shipping Weight: 14 lbs. (6.33kg)



DA400R AIR COMPRESSOR (1/6 H.P.)
1/6 H.P. Piston Compressor with Auto shutoff. Compressor shuts off when airbrush is not in use. Operating pressure 30 - 50 PSI depending on airbrush being used, delivers up to 55 psi. 110-120VAC, 1 Ph, 60 Hz, 42L/Min. (1.48CFM), 1720 rpm. With R-75 Regulator & Moisture Trap included.

Shipping Weight: 12.2 lbs. (5.6 kgs)